

**CSE 140, Winter 2005**

**Midterm 1  
Thursday 01/27/2005**

**Order all terms in sum of product terms/subcubes in alphabetical order.**

**i.e. Write  $ACD + B'C'D$**

**NOT  $CDA + B'DC'$  or any other order.**

**Answers with out-of-order terms will be deducted  $\frac{1}{2}$  point.**

**Circle your answers!**

1	10
2	15
3	10
4	10
5	10
6	5
Total	60

**1) Critical Path & Timing Analysis. (10 pts)**

a.) Find the critical path through the sets of gates. If there is more than one critical path, identify all of them. Inputs are a,b,c,d,e and output is o (5 pts).

Use the following delays:

- XOR, 3 input AND and NAND = 4ns
- 2 input AND and OR = 2ns
- NOT = 1ns

Your answer should be of the form:

*Critical Path = a-> h-> t-> .... etc*

*Total delay = 2 + 2 + 2 + ... etc*

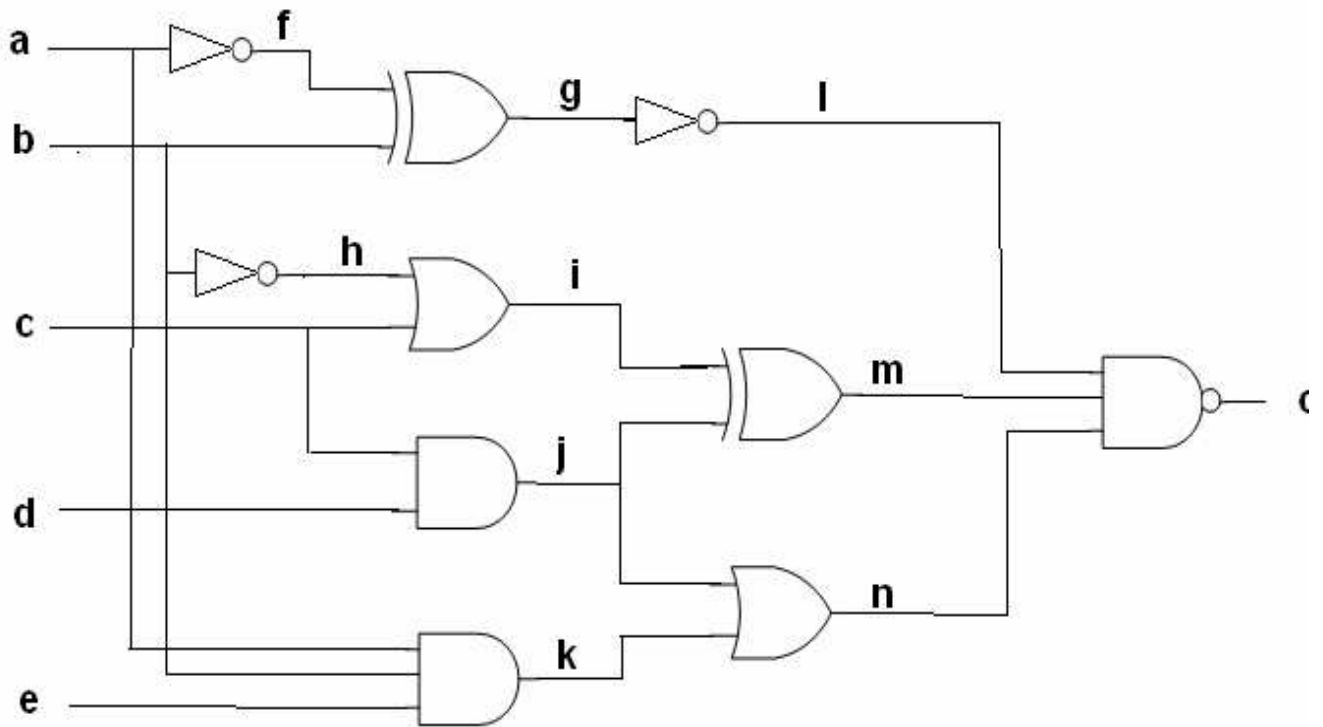

Critical Path: b -> h -> l -> m -> o

Total Delay: 1+2+4+4=11ns

b.) Please draw the wave form for the input values given in the following diagram. (5 pts)

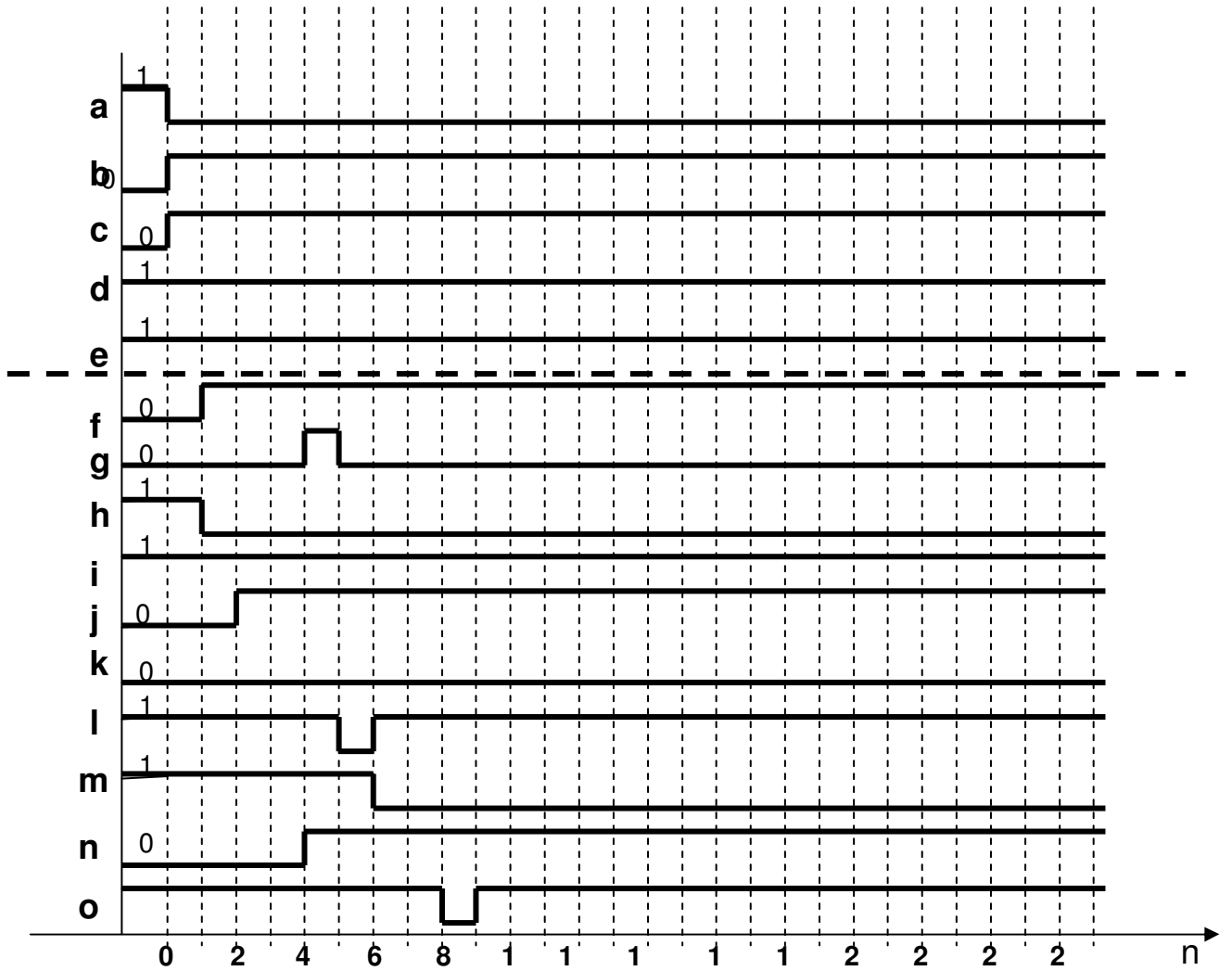



Prime Implicants:

$b'c'$ ,  $b'd'$ ,  $ad'$ ,  $a'c'd$ ,  $a'bd$ ,  $bcd$ ,  $abc$

b) Find the **essential prime implicants** (3 pts)

Essential prime implicants:  $b'c'$  ,  $b'd'$

c) Find a **minimum cover** (5 pts)

$$F = b'c' + b'd' + abc + a'c'd$$

OR

$$F = b'c' + b'd' + abc + a'bd$$

3) Let  $F' = (a + b')(b' + c')(a' + c)$

a) Use De Morgan's Law to derive  $F$  in Sum-of-Products form. (2 pts)

$$F = a'b + bc + ac'$$

Then implement  $F$  using a NAND/NAND diagram (4 pts)

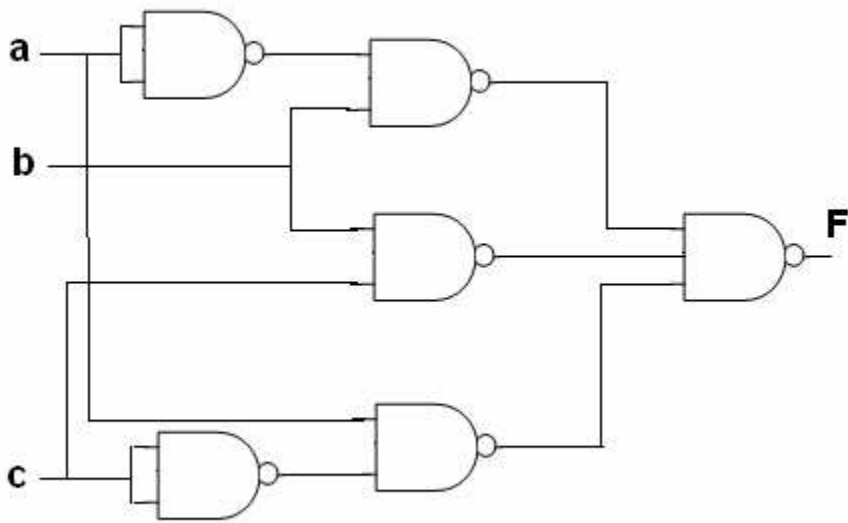

b) Implement the function **F** using a NOR/NOR diagram (4 pts)

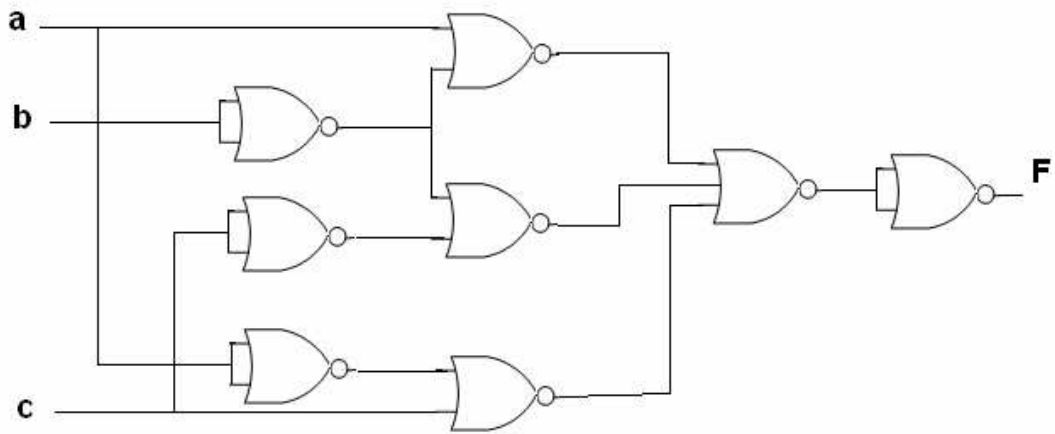

4) Given below is a 4-variable K-map and a possible minimum cover is shown in the table. This question concerns the identification of the static hazards and the minimum hazard-free two-level logic implementation. **Consider only static-1 hazards and single-input-change.** (10 pts)

a.) Given the prime implicants in the following K-map, please identify all possible single-input-change transitions that may result in static-1 hazards. (5pts)

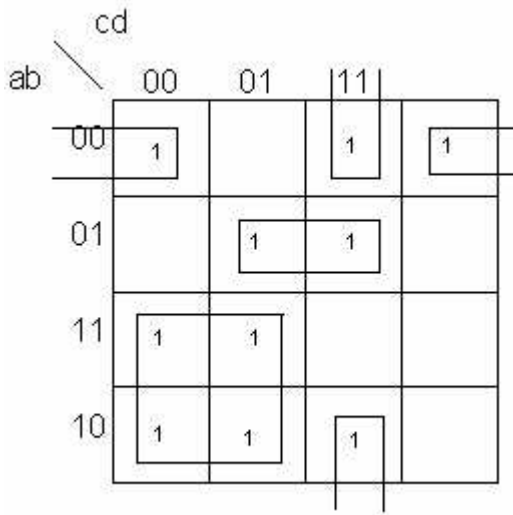

abcd: 0000  $\leftrightarrow$  1000

0011  $\leftrightarrow$  0111

0011  $\leftrightarrow$  0010

0101  $\leftrightarrow$  1101

1001  $\leftrightarrow$  1011

- b.) Find a minimum hazard-free two-level implementation for the same function in part (a). Provide **both** the k-map and minimum product of sum representation. (5 pts)

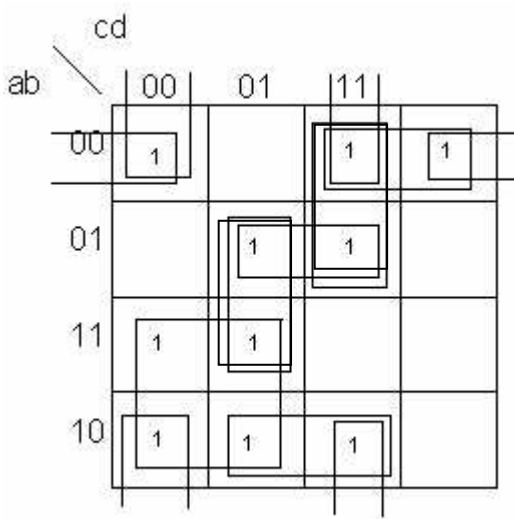

$$F = a'b'd' + b'cd + a'bd + ac' + b'c'd' + a'b'c + a'cd + bc'd + ab'd$$

5) Minimize the number of literals for the following multi-level logic functions and specify the number of literals for your solution. (10 pts)

a) (5 pts)

$$M = AB + AC + BC$$

$$N = AE + BC + CE$$

$$P = AC' + AD + CD + D'$$

$$X = A + C$$

$$M = B(A + C) + AC = BX + AC$$

$$N = E(A + C) + BC = EX + BC$$

$$P = A + C + D' = X + D'$$

b) (5 pts)

$$M = AB'C + BC + C'$$

$$N = AC'D'E' + A'BC'D'E'$$

$$P = AC + AD + BC + BD + AE + BE$$

$$X = A + B$$

$$Y = C + D + E$$

$$M = AB'C + B + C' = AC + B + C' = A + B + C' = X + C'$$

$$N = C'D'E'(A + A'B) = (C + D + E)'(A + B) = XY'$$

$$P = A(C + D + E) + B(C + D + E) = (A + B)(C + D + E) = XY$$

6) You are required to implement the function  $F$  as shown in a black box in the following figure. This particular function has three inputs (M, N, P) and one output (O). (5 pts)

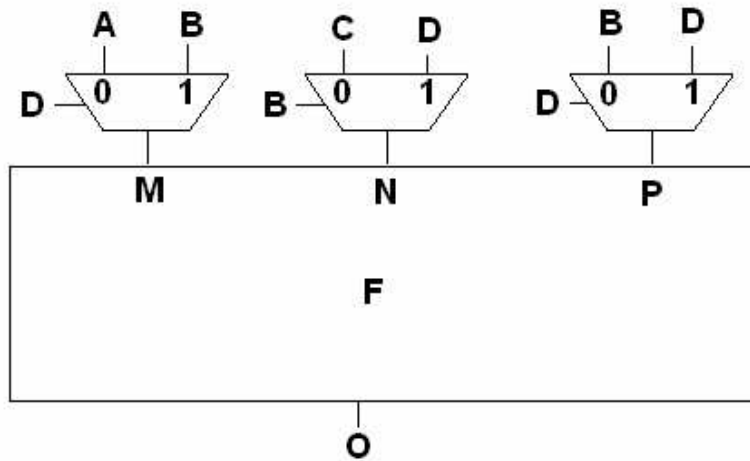

The truth table for the overall function (O) as a function of (A, B, C, D) is specified as follows:

<u>ABCD</u>	<u>O</u>
0000	0
0001	1
0010	1
0011	0
0100	1
0101	0
0110	1
0111	0
1000	1
1001	1
1010	0
1011	0
1100	0
1101	0
1110	0
1111	0

Given this particular truth table, please identify the *truth table for the function F* as a function of (M, N, P) only.

<u>M N P</u>	<u>Q</u>
0 0 0	<b>0</b>
0 0 1	<b>1</b>
0 1 0	<b>1</b>
0 1 1	<b>0</b>
1 0 0	<b>1</b>
1 0 1	<b>0</b>
1 1 0	<b>0</b>
1 1 1	<b>0</b>